



SNL48V30GC User Manual



CONTENTS

<i>1. Safety</i>	<i>1</i>
1.1 Instruction	1
1.2 Standard	1
1.3 Important safety information	1
1.4 Battery Maintenance	2
1.5 Waste Treatment.....	2
<i>2. Introduction to the Invicta 48V Golf Cart battery</i>	<i>2</i>
2.1. Key Features.....	2
2.2. Product Appearance	2
2.3 Functional characteristics.....	3
<i>3. Installation</i>	<i>4</i>
3.1 Tool And Equipment	4
3.2. Battery placement	4
3.3 Supporting parallel connection	5
3.4 Connection mode of battery communication port	6
<i>4. Charging requirements</i>	<i>7</i>
4.1Charging with an AC-DC Battery Charger.....	7
4.2Charging with Solar	7
4.3Charging with an Alternator via a DC-DC Charger	7
4.4 Recommended charging voltage	7
4.5 Equilibrium	Error! Bookmark not defined.
<i>5 Battery Recyclable</i>	<i>8</i>



1. Safety

1.1 Instruction

Please read the user manual carefully before installation, operation and maintenance, and pay attention to various warning boards and warning statements on the equipment. Please keep it for future reference after reading the user manual,

1.2 Standard

The following marks are used in the user manual to indicate where the special attention should be paid during operation.

Marked Symbol	Expound
	CAUTION, WARNING: Call attention to something
	DANGER: Warning of electric shock risk
	INSTRUCTION, HINT: It's need to be special instructions or hints

1.3 Important safety information

The following operating and maintenance instructions must be read before installing, operating or maintaining the battery.

Before installation :

- It is very important and necessary to read the user user manual carefully before installing or using the battery. Failure to follow any of the instructions or warnings in this document can result in electrical shock, serious injury, or may damage the battery and the whole system.
- Before connecting the battery packs to your equipment, check the voltages and ensure that they are within the limits of your equipment specifications. Failure to observe these specifications could void your warranty.
- We recommend charging each battery to 100% prior to installation.

Installation :

- We recommend using a golf cart technician when installing the battery. For best safety, follow the steps described in this manual
- The ambient conditions given in the product documentation must be observed.

Operating the battery /:

- It is prohibited to connect the battery with a different type of battery;
- A Invicta Lithium Charger with matching required voltage must be used;
- Long term floating charge is prohibited for lithium ion batteries
- The ambient conditions given in the product documentation must be observed.
- Keep the battery away from fire or water.

1.4 Battery Maintenance

- During the charging process, ensure that the plug and socket is connected, that the charging equipment works normally, and that the connection points of the battery pack are in good contact. In case of abnormality, it needs to be repaired before charging;
- If there is a large amount of dust, metal chips or other sundries on the upper cover and terminals of the battery pack, clean it with compressed air. Avoid cleaning with water or water soaked objects;
- When charging and discharging, try to avoid splashing water or other conductive objects on the upper cover and terminals of the battery, such as being exposed to heavy rain.
- Estimate the charging time and discharging time of the battery according to the actual use state of the battery or battery pack. At the end of charging and discharging, pay attention to observe whether there are abnormalities in the battery or battery pack.
- Once a month, check whether terminals and other nodes are loose, falling off, rusted or deformed, so as to ensure the series and parallel connection of the battery pack.

1.5 Waste Treatment



Please dispose of the package and replaced parts according to the rules applicable in the country where the device is installed.

Do not dispose the battery with normal domestic waste.

2. Introduction to the Invicta 48V Golf Cart battery

2.1.Key Features

- LiFePO4 composition – provides exceptional safety and longevity
- High safety and reliability
- Consistent performance over wide temperature range

This battery has accelerated passive cooling and can maintain a high current charge and discharge for a longer time.

This battery can communicate with external devices through CAN and Bluetooth to better manage the battery.

2.2.Product Appearance

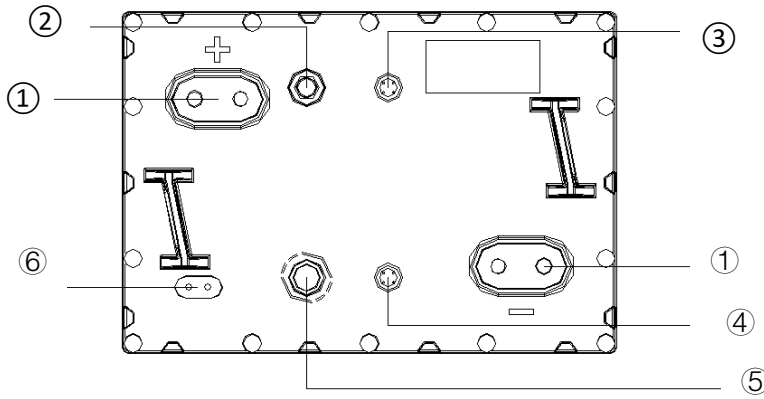

1.	Positive and negative terminals
2.	Explosion proof valve
3.	Communication port1
4.	Communication port2
5.	Isolation Switch
6.	LED

Fig1 Outline drawing

2.3 Functional characteristics

Item	Specification	Item	Specification
Rated voltage	51.2V	Size	260*180*272mm
Rated capacity	30AH	Communication	CAN/RS485
Standard Charging voltage	55.2V~57.6V	Weight	~15.5KG
Max continuous charging current	30A	Working temperature	Charger : 0°C-45°C
Standard charging current	10A		Discharge: -20°C-65°C
Maximum continuous discharge current	60A	Short circuit protection	500A/366ms@close battery
Peak discharge current / time1	65A/30S	Self discharge rate	<3%/month
Peak discharge current / time2	100A/10S	Cycle life	6000times@80%DOD 25°C
Discharge cut-off voltage	44.8V	Shell material	ABS+PC /UL94-V0
IP Grade	IP67	Pack certification	UL2271/CE/UN38.3/Class 9
Series and parallel connection	Max.10pcs battery parallel , series is not allowed.	Cell certification	UL1642/UL2580/UN38.3

2.3.1 First use

- When the battery leaves the factory, the isolation switch will be turned off and in the off state,
- Before use, the switch needs to be switched to the on state, and the LED indicator lights up.
- Before multiple batteries are connected in parallel, a multimeter shall be used to test the voltage at both ends of the positive and negative poles of the battery to ensure that the voltage difference between the batteries does not exceed 2V.
- If the voltage difference between batteries exceeds 2V, each battery shall be fully charged separately and then used in parallel.

2.3.2 LED description

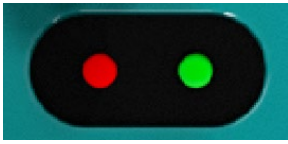

LED indicator, one red and one green

The red light indicates that a fault is displayed. Under normal conditions, the indicator is not on. When a fault occurs, the indicator is on. The green light indicates different SOC according to different blinking modes.

SOC	Lighting mode
$\leq 20\%$	On "0.3s" / off "0.7s"
20%-90%	On "1s" / off "1s"
$\geq 90\%$	Green light constant

2.3.3 Communication port

- 2 communication ports, with CAN communication and RS485 communication;
- The battery can be upgraded through the communication port
- It can communicate with other devices through the communication port, and the communication protocol needs to be deployed before communication

2.3.4 ON or OFF

Invicta 48V GOLF CART has an isolation switch. When the battery is transported or stored for a long time, this can be turned off. This ensures there is very low self-discharge, so the battery can be stored for a long time and improve the safety of the battery.

3. Installation

3.1 Tools And Equipment



Insulating Gloves



Safety Shoes



Spanner

3.2. Battery placement

Gently place the battery pack on the support surface with the front side up, do not place it on the side or upside down, and do not place any covering above the pack. The schematic diagram of battery pack placement is shown in Figure 3

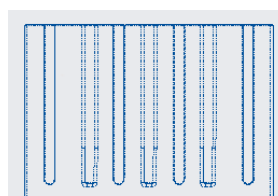

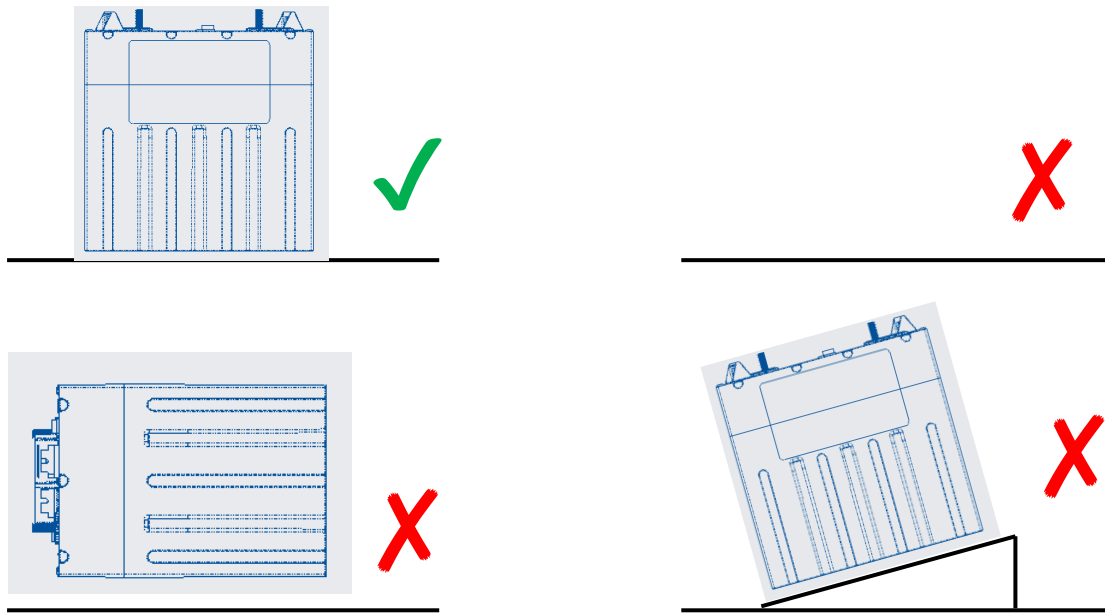

Fig 3 Battery placement

3.3 Parallel Connections

INVICTA 48V GOLF CART allows up to 10 batteries to be used in parallel. Before parallel connection of batteries, use a multimeter to test the voltage at both ends of the positive and negative electrodes of the batteries, and ensure that the voltage difference between batteries does not exceed 2V. If the voltage difference between batteries exceeds 2V, each battery shall be fully charged separately and then used in parallel.

1. Precautions for parallel connection

- A. The parallel battery pack must have the parallel function; The parallel connected battery packs must be products of the same model and part number.
- B. Ensure the length of all parallel wires is consistent;
- C. We suggest using 0.5C for charging, that is, charging current=battery rated capacity * 0.5C
- D. When the battery packs are used in parallel, the open circuit voltage of each group of batteries must be highly consistent. It is recommended that the voltage difference between battery packs be:
Voltage difference < 2000mV (@ 0%~95% SOC)

When the voltage difference is less than 1500mV (@ 96%~100% SOC), the battery pack will be charged and discharged as a whole after being connected in parallel. If one of the batteries needs to be replaced, it is recommended that all battery packs be replaced at the same time

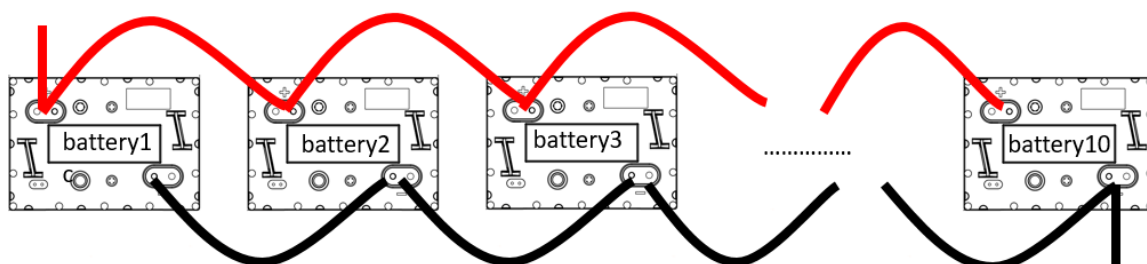

Two 51.2V batteries rated at 30Ah connected in parallel

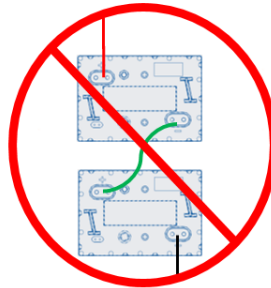
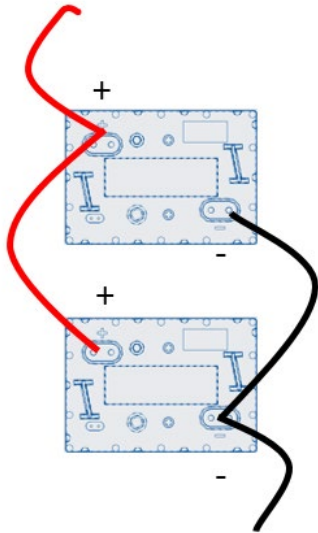

! Do not use the battery in series, which may permanently damage battery.

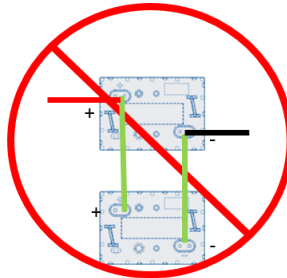

! Do not output positive and negative poles on the same battery, which may damage the battery.

System Voltage: 51.2V

System Capacity: 30Ah + 30Ah = 60Ah

3.4 Connection mode of battery communication port

1.CAN

The battery includes a Controller Area Network (CAN) bus communication interface. Two round M8 DIN connectors are located on the top of the battery to connect one battery to the other using CAN bus cables in a simple daisy chain format.

The CAN bus function is not required for normal battery operation. Automatic operation and protection of battery; It does not require any CAN bus communication or external devices (such as external controllers) or other batteries connected to the CAN bus to work. Keep the two black covers installed on the two M12 connectors to protect them from the environment when not in use.

On-site service can retrieve the battery use history and view the status through the can bus interface for diagnostic assistance.

1. Communication wiring diagram

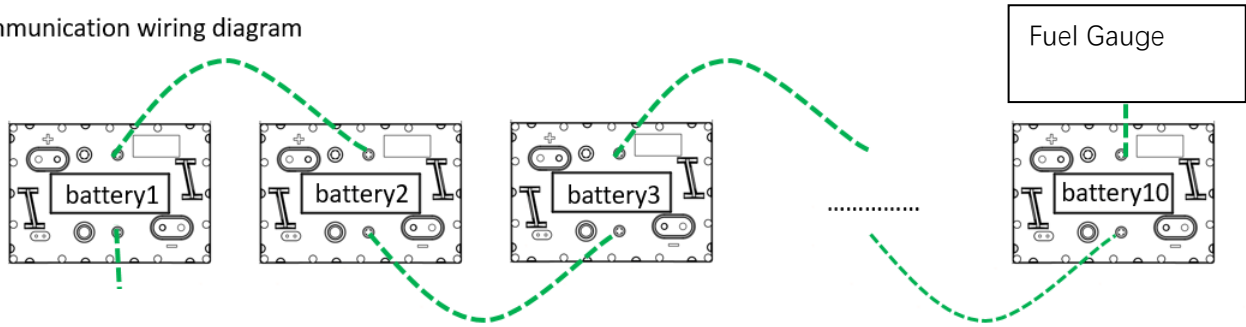

Each group of batteries is equipped with a special communication line, which is connected by CAN bus. This ensures the battery can communicate with the load or charger for more efficient use of the battery. This also can allow a service assistant to better understand the battery failure. If you have more questions about the CAN bus, please contact Invicta's engineers for technical support.

4. Charging requirements

We recommend using an Invicta Lithium Charger that meets the charging requirements below for maximum performance and lifespan of the INVICTA series battery.

Model	Max Charge Voltage	Cut-off Voltage	Maximum Charge Current	Recommended Charge Current	Operation Temperature
48V	57.6V	40V	1C	0.3C	Charge: 0~45°C
					Discharge: -20~65°C

4.1 Charging with an AC-DC Battery Charger

Check the AC-DC battery charger you intend to use has a dedicated lithium charge setting that meets the above charging requirements. A lot of battery chargers are designed for charging lead-acid batteries only and may not have a suitable charge setting for lithium. If unsure always contact an expert for advice.

4.2 Charging with Solar

Check the solar regulator you intend to use has a dedicated lithium charge setting that meets the above charging requirements. A solar regulator without a lithium charge setting may be used to charge the INVICTA series battery. However, it must be set to charge no higher than 58.4V and then MUST be switched off once the INVICTA series battery is fully charged. DO NOT leave a solar regulator switched on without a suitable lithium charge setting once the battery is fully charged.

4.3 Charging with an Alternator via a DC-DC Charger

Check the DC-DC Charger you intend to use has a dedicated lithium charge setting that meets the above charging requirements. A DC-DC charger without a lithium charge setting may be used to charge the INVICTA series battery. However, it must be set to charge no higher than 58.4V and then MUST be switched off once the INVICTA series battery is fully charged. DO NOT leave a DC-DC charger switched on without a suitable lithium charge setting once the battery is fully charged.

4.4 Recommended charging voltage

The recommended charging voltage is set between 55.2V and 57.6V. It is strongly recommended an Invicta Lithium Charger is used to charge the battery.

5. Battery Monitoring (wired/wireless)

To monitor your battery information there are two options available which connect to the CAN communication ports.

1. Invicta digital CAN monitor (wired)

The Invicta digital monitor gauge can be connected to a CAN communication port on one of your batteries via a wired connection. The gauge can then be installed in a suitable location which is easily visible to the user. Ensure the CAN bus resistor is installed on the battery.



52.7V	Represents battery voltage
20.5A	Represents the current value of the battery, and "-" is for discharge; '+' is for charging
75%	SOC: State of Charge, Remaining battery capacity
Alarm 1	Fault codes, from '1' to '10'
Err	Communication Failure

The lithium battery is equipped with an intelligent BMS, which can effectively protect the battery cell and avoid unsafe accidents. In order to better protect the battery cell, the BMS will report some alarms, but sometimes the alarm information does not require additional processing. It can be used normally or simply indicates that the battery is low and needs to be charged as soon as possible. In short, the alarm information does not necessarily indicate a battery malfunction.

Alarm Number	Alarm number analysis	Suggested handling method
Alarm 1	Single cell high voltage	About to be fully charged
Alarm 2	Single cell low voltage	Timely charging
Alarm 3	Total high voltage	About to be fully charged
Alarm 4	Total low voltage	Timely charging
Alarm 5	Large voltage difference cell	Charging with low current, charging current < 0.5C
Alarm 6	Discharge overcurrent	Reduce load or increase battery capacity
Alarm 7	Charge overcurrent	Reduce charging current, charging current < 1C

Alarm 8	High temperature alarm,	Reduce load or increase battery capacity to avoid direct sunlight
Alarm 9	Low temperature alarm	Charging environment > 0 ° C
Alarm 10	Large temperature difference cell	Check if the battery connection wire is loose
Alarm 11	Low SOC	Timely charging
Err	Abnormal communication	check if the communication cable connection between the batteries is normal.

2. Invicta Bluetooth CAN monitor

The Invicta CAN Bluetooth monitor device can be connected to one of the CAN ports on your batteries. When used in conjunction with the Invicta app, the battery information can be displayed on your mobile device, such as mobile phones or tablets via Bluetooth connection.

Note: The Invicta digital CAN monitor and Invicta Bluetooth CAN monitor can be used simultaneously.

For more information on monitoring options or assistance please contact the Sealed Performance Batteries team

6. Battery Recyclable

Invicta® 48V GOLF CART Lithium-Ion batteries are recyclable and should not be disposed of as household or landfill waste. If you need assistance in recycling your battery, contact your dealer or Invicta's technical support engineers as outlined at the front of this manual.

7. Contact Details and Information

A range of resources can be found at <https://www.invictalithium.com.au/>. This includes specifications, product registration and our warranty statement. If you require any further assistance with your Invicta battery, please contact the team at Sealed Performance Batteries (SPB) on 07 3886 1102 or sales@spb.net.au.

Invicta is a trademark of Sealed Performance Batteries, a company that has over 25 years of experience in energy storage and are located in Brisbane, Sydney and Melbourne. For more information on Sealed Performance Batteries please visit <https://www.sealedperformance.com.au/>.

